

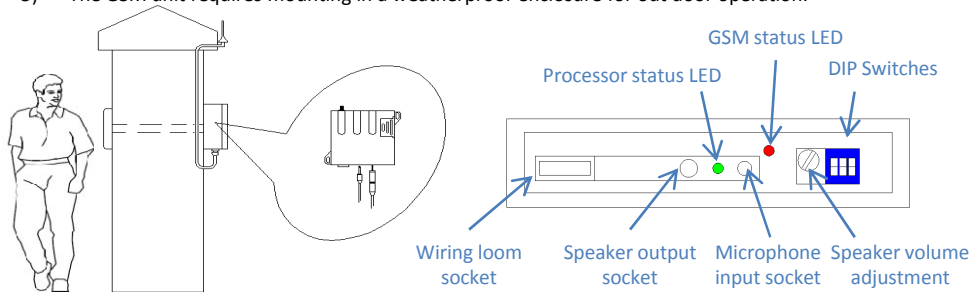

- 1) Please read this entire manual before attempting to install this system.
- 2) Always ensure that the power is switched OFF before inserting or removing a SIM card.
- 3) When mounting the intercom, position the call point as close to head height as possible (1600mm from ground level).
- 4) To minimise GSM Rf interference on the call, position the GSM unit as far away from the call point as possible, and install the GSM antenna away from both mentioned items in a prominent elevated position if possible.
- 5) The GSM unit requires mounting in a weatherproof enclosure for out door operation.



Switch	Application	ON	OFF
1	Programming mode	Enabled	Disabled
2	Automatic tel no learning or manual number entering (normally ON)	Normal	Automatic
3	Relay output function (Usually off for automatic gates)	Latching	Pulse

SIM Card

Choose a SIM card which has the best reception in the area. Poorer reception areas will cause the GSM unit to boost it's Rf output power, which will increase the amount of GSM hum or interference which can be heard on the call.

If you are using a pay and go SIM card, please ensure that the unit has adequate calling credit before installing into the unit. Please also ensure that there are no ring back features enabled or call divert.

Telephone Number Memory Locations

Location	Function / Description
000	Master programmer location. Any number stored here will be able to reprogram the unit without needing to attend the site and switch on DIP switch 1.
001	First telephone number which the intercom will call when a visitor presses the call button. Number stored here will also be able to ring the unit to open gate/door.
002	Second number which will only be called if there is no answer at the first. Number stored here will also be able to ring the unit to open gate/door.
003	Third number which will only be called if there is no answer at the first or second. Number stored here will also be able to ring the unit to open gate/door.
004 - 999	Numbers stored in these locations can call the unit to gain access at no call charge. I.e. Call your gate / door to open. The unit will recognise the number, trigger the output relay, and hang up without answering the call.

Notes:
Speaker cable is not polarised. MIC cable is polarised, and must be connected as shown with screen connected to terminal 2, and the centre core to terminal 1.

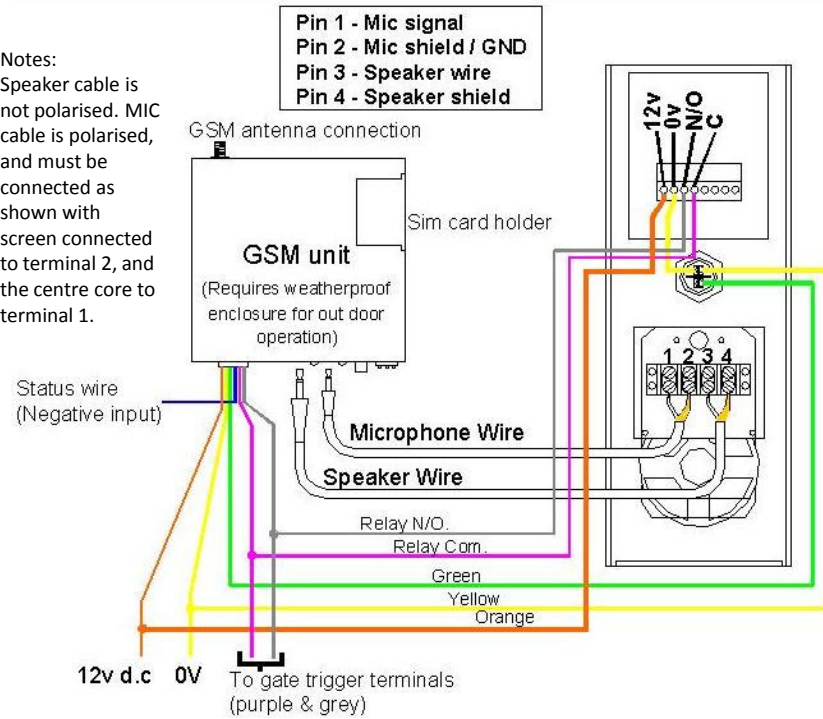

Programming

- 1) To begin programming, ensure that DIP1 is ON, enabling programming mode. and DIP 2 is ON enabling manual programming mode (most popular method).
- 2) Ring the unit from the master telephone number which you intend to use for maintenance etc. Once the GSM unit answers, you will hear a long acknowledgment tone.
- 3) Enter the following sequence to clear the SIM card from all data and numbers...
* 4 * * * #
- 4) The unit will now hang up. Redial the intercom number to re-commence programming.
- 5) Enter the following sequence to program in the master telephone number...
0 0 0 * ? - ? #

After entering each number, the unit will play an audible message, repeating the number back to you.

6) Repeat this process for memory location 1, entering the number you want the intercom to dial when a visitor arrives, and if required, repeat for locations 2 and 3.

As described in table 3, locations 4 to 999 can be used to store numbers which can ring the intercom to gain access at no call charge.

7) When finished, PLEASE ENSURE TO SWITCH OFF DIP SWITCH 1, SO THAT THE UNIT WILL RETURN TO NORMAL OPERATION MODE BEFORE TESTING. Once the master number has been entered, the master number can ring the unit and change programming at any time, even with DIP switch 1 OFF.



Keypad Programming

setting the programmers code

Factory set code is 1234

- 1.1) With the power off press and hold down the * key
- 1.2) Connect power and continuous tone sounds.
- 1.3) When the tone stops release the * key and enter your new 4 digit Programmers Code.
- 1.4) A two second confirmation tone sounds after the 4th digit is entered.

____ _
new Programmers Code

entering programming mode

- 2.1) Press * and then enter the 4 digit Programmer Code.
- 2.2) When the correct Programmer Code is entered then the sounder & LED will pulse and the lock relay will change state.
- 2.3) To exit Programming Mode press the * key.

setting the lock time

Factory set time is 05 seconds

- 3.1) Enter Programming Mode.
- 3.2) Enter 00 (this selects special location 00).
- 3.3) Enter the desired lock/relay operation time in a two digit format (01 to 99 seconds).
- 3.4) The code lock will return to the Programming Mode Base Level.
- 3.5) Press * to exit Programming Mode.

adding user codes

Factory set code in location 01 is 6789

- 4.1) Enter Programming Mode.
- 4.2) Enter the location 01 to 41 (31-40 are the latching code locations). If a series of bleeps are heard at this point then the location has a code stored, you may proceed as this is only a warning tone.
- 4.3) Enter the desired 4 Digit User Code, If the code lock returns immediately to the Programming Mode Base Level then the code is not permitted as it already exists elsewhere in another location. If the code is permitted then a 2 second confirmation tone will be heard.
- 4.4) Return to Step 2 to enter more User Codes or press * to exit Programming Mode.

deleting user codes

- 5.1) Enter Programming Mode.
- 5.2) Enter the desired location (01 to 40), If a series of bleeps are heard at this point then the location already has a code stored, you may however proceed as this is only a warning tone.
- 5.3) Press the # key to delete the code from the location, a 2 second confirmation tone will be heard.
- 5.4) Return to step 2 to delete more codes or press * to exit Programming Mode.

Testing

- 1) After programming is complete, press the call button. The speaker will announce "please wait, your call will be answered shortly". The unit will then dial the first number in the calling list.
- 2) Answer the call and check that 2 way audio is present. Note, if echo is experienced on the call, reduce the volume control on the GSM unit. Most loudspeaker GSM audio systems experience some GSM hum. If there is excessive hum, try changing the SIM card to another network provider who may have a mast located closer to the site.

Additional Features

- 1) When the master user calls the SIM in the GSM unit, it will answer the call to allow access to programming features. To activate the relay form the master number enter.....



- 2) To set the maximum number of rings the unit will make before cancelling the call and attempting the next number. (can be from 1 to 9 rings)..



1-9

- 3) The unit can be locked and unlocked by the master user so that no one else can use it.



Lock

Unlock

- 4) To determine the next available free memory location (the unit will audibly announce the result).....



Trouble Shooting

- 1) The GSM unit will not boot up. **A – Check power source is correct and polarity is good.**
- 2) The GSM unit will not answer my call. **A – Check SIM card is installed correctly. Check the SIM card can be called when installed in a mobile phone. If not, it may need registered and credit applied. If the SIM card functions normally, check the DIP switch 1 is ON for programming mode. Note: Phones that with hold their number cannot call the unit either for programming or to open gates etc.**
- 3) The unit can be programmed normally, but the call button does not work. **A – Check the power source is d.c. Check wiring.**
- 4) The unit works and programs OK but does not work in a specific location or site. **A – Check the reception of the SIM card in a mobile phone at the customer's site.**
- 5) The unit is operational but loud buzzing or hum interference can be heard on the call. **A – Ensure that the antenna is positioned well away from the GSM module, and that the antenna cable is unfolded and straightened out. Excess cable should not be left close to the GSM module. Change SIM card provider to one with a closer base station. If this is not possible, or does not help, fit our high gain cellular antenna (GSM-ANT3) which will help improve signal and audio quality. Note that a nominal amount of GSM buzz is normal .**
- 6) I can hear echo from the internal unit or phone. **A- Some models can suffer from echo if the volume of the speaker is too high. Reduce the volume control on the module. It may also be possible to insert foam or sound absorbing material like cloth inside the call point for applications where very loud volume is required.**